

# Axellent Assembly instructions

» FlexCore Guardrail

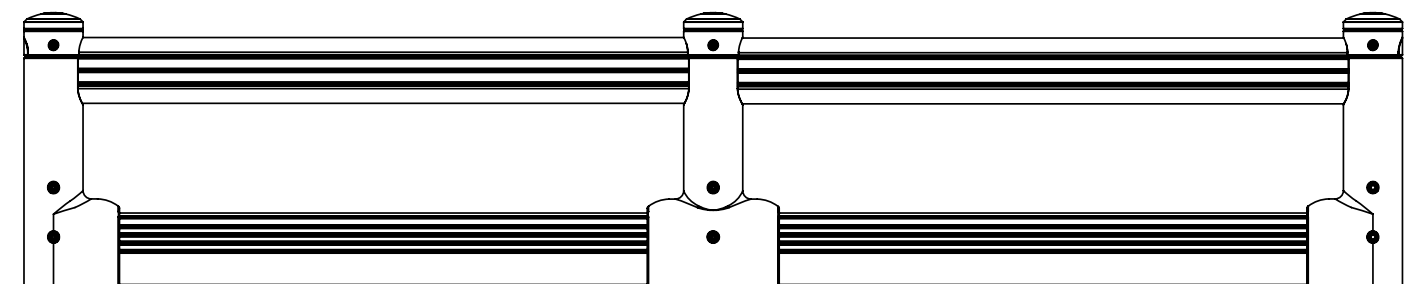

## Components

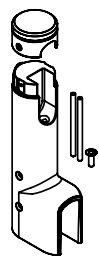

End Post Kit  
M033-084-  
018E

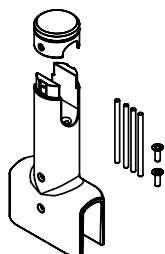

Mid Post Kit  
M033-084-  
018M

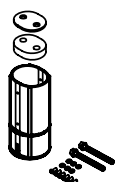

Core Kit  
GR-K-COR

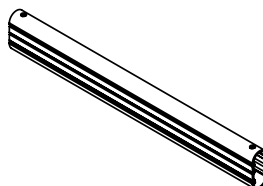

Top Rail  
M021-023-300T

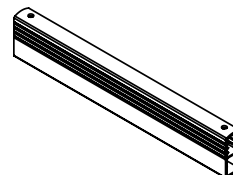

Lower Rail  
M021-023-  
300B

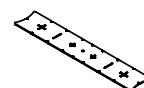

Template  
GR-C-TMP

\*Some components included within "M" bundles.

## Tools required



Tape  
Measure



Marker



Chalk Line



Rotary  
Hammer



Masonry  
Drill Bit  
25mm/16mm



Corded Drill



Socket &  
Extension  
27mm



5.5mm  
Hex Key



Drill with  
5.5mm  
Hex Bit

# Axellent Assembly instructions

» FlexCore Guardrail

## Modular Product

This is a modular Guardrail system and each installation requires it's own custom layout. Please read entire installation instructions before beginning your installation. If you require additional information, please contact Axellent Safe-X customer support for assistance.

## Template Instructions

Use the template to accurately mark hole locations for drilling. Steps that require the template will be labeled the template icon.

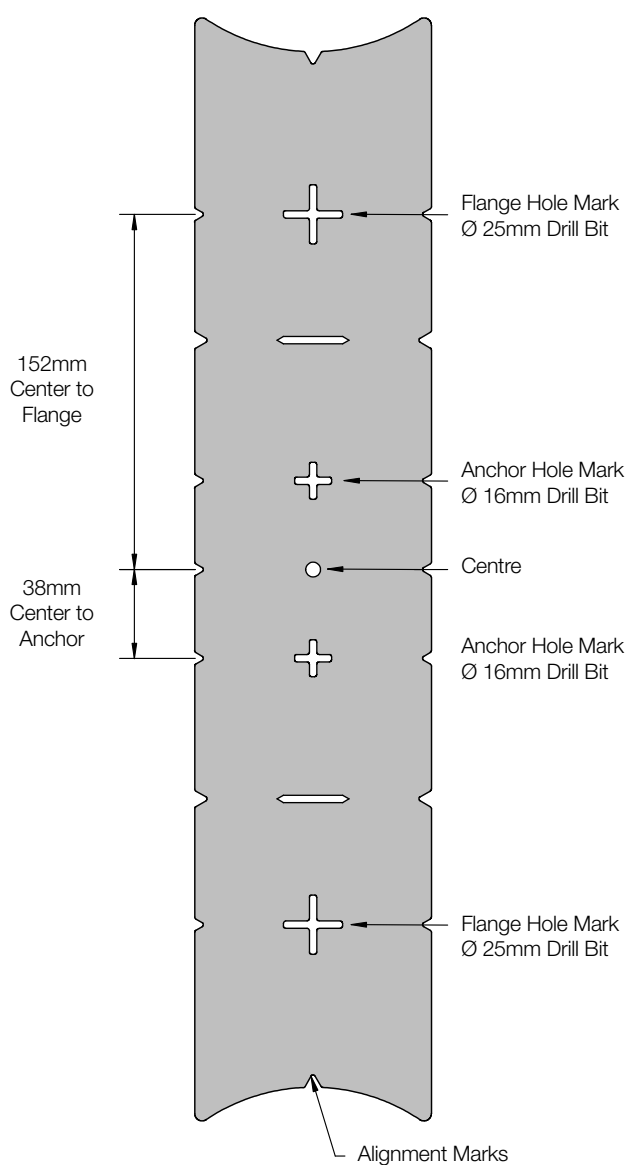

# Axellent Assembly instructions

## » FlexCore Guardrail

- 1 Attention:** If section is less than 3048mm center to center, see cutting instructions.

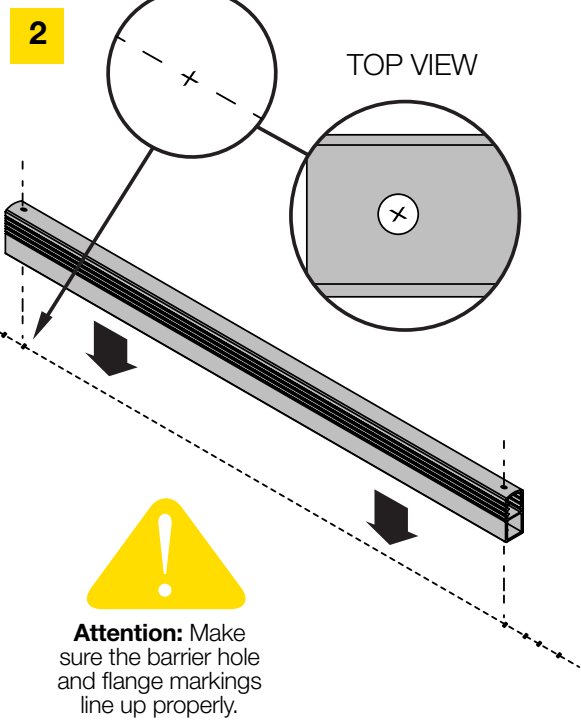
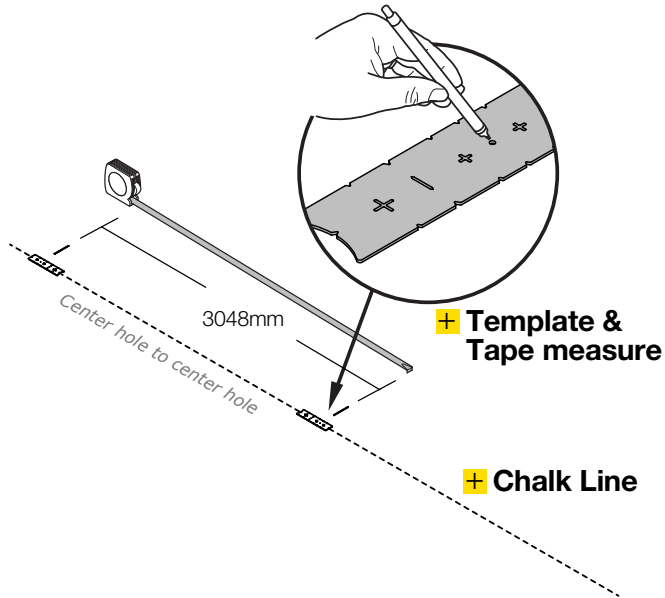

**3**

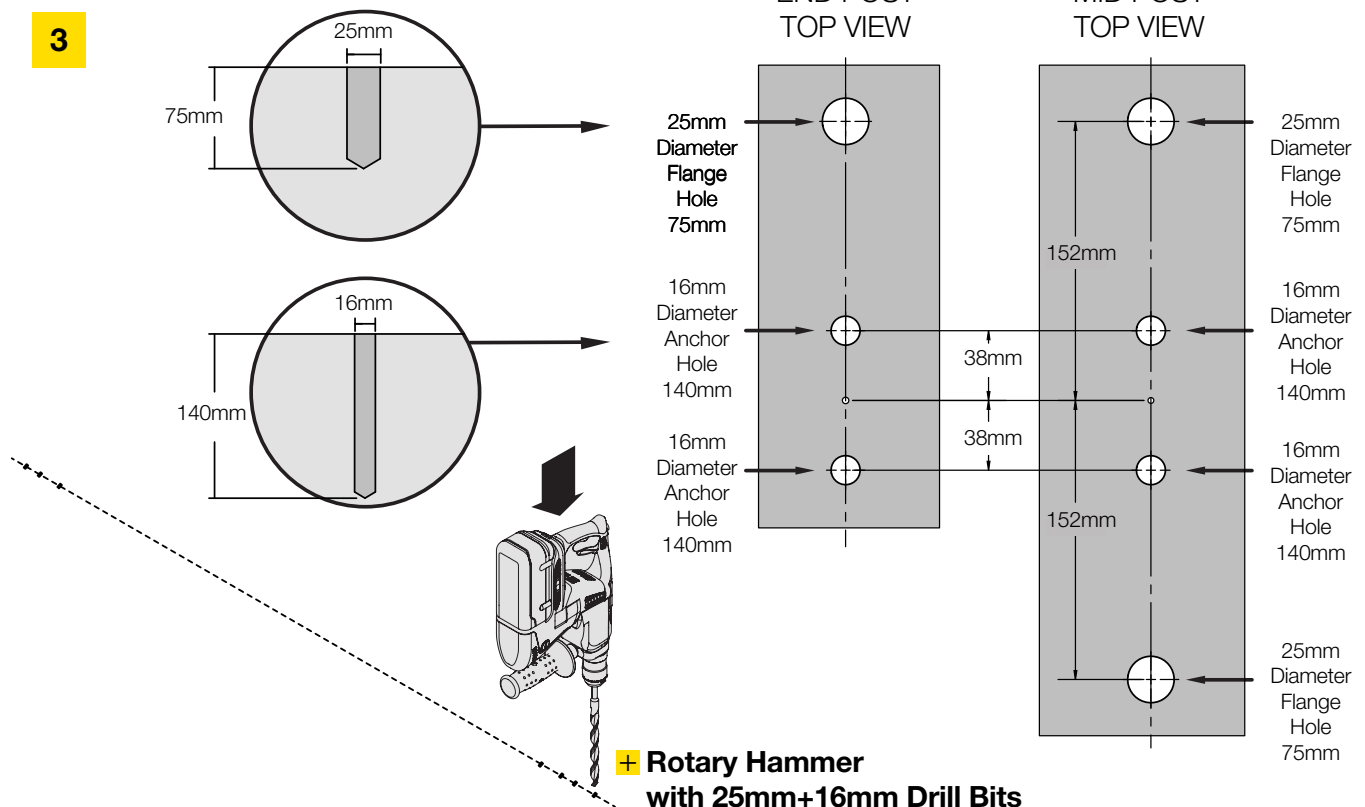

# Axelent Assembly instructions

## » FlexCore Guardrail

**+ Impact Driver with  
27mm Socket**

**4**

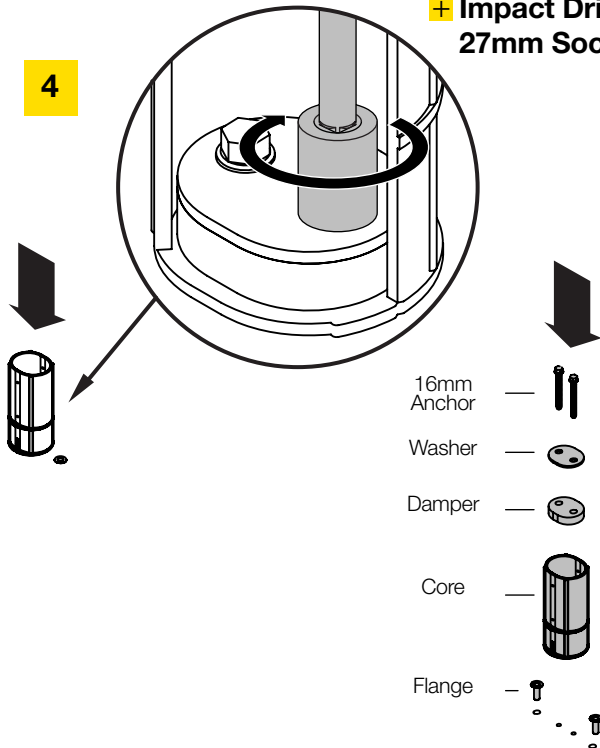

**5**

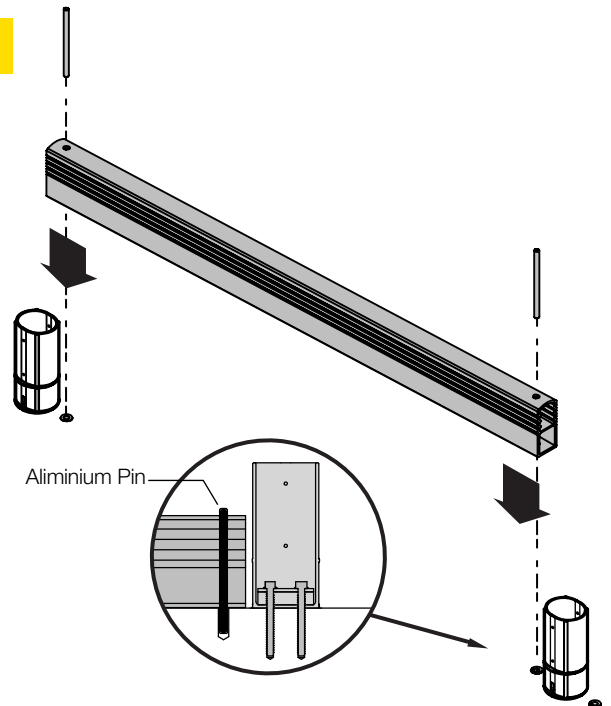

**6**

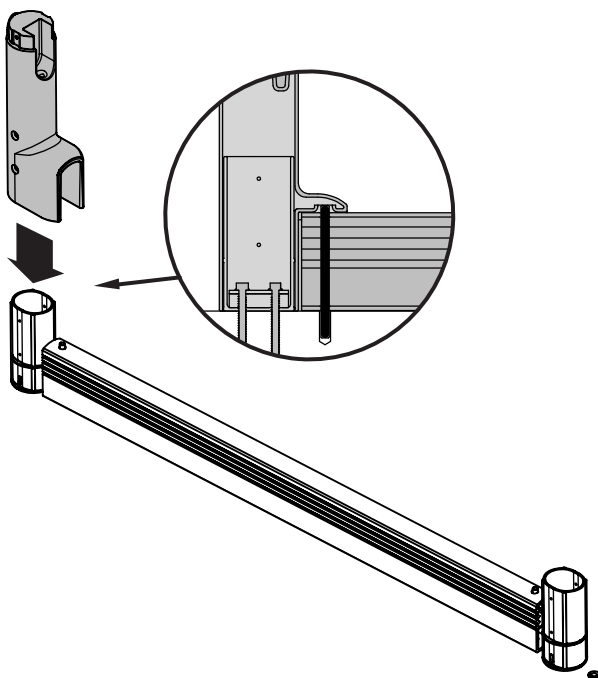

**7**

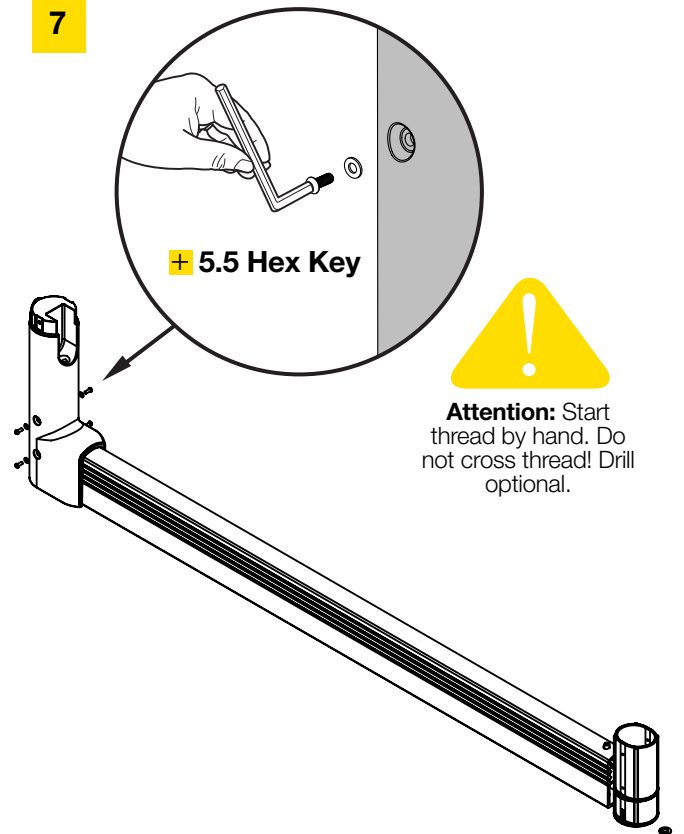

# Axelent Assembly instructions

» FlexCore Guardrail

8

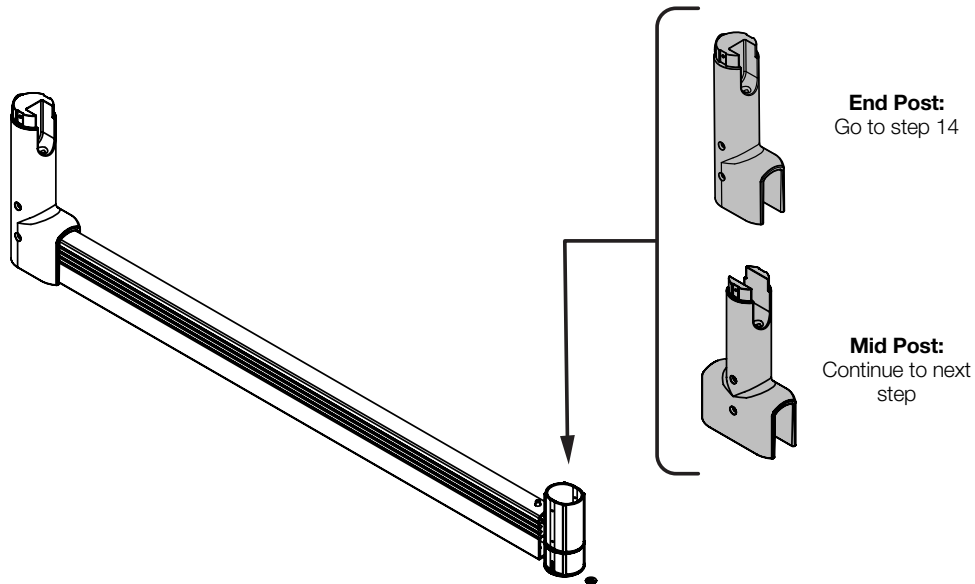

9

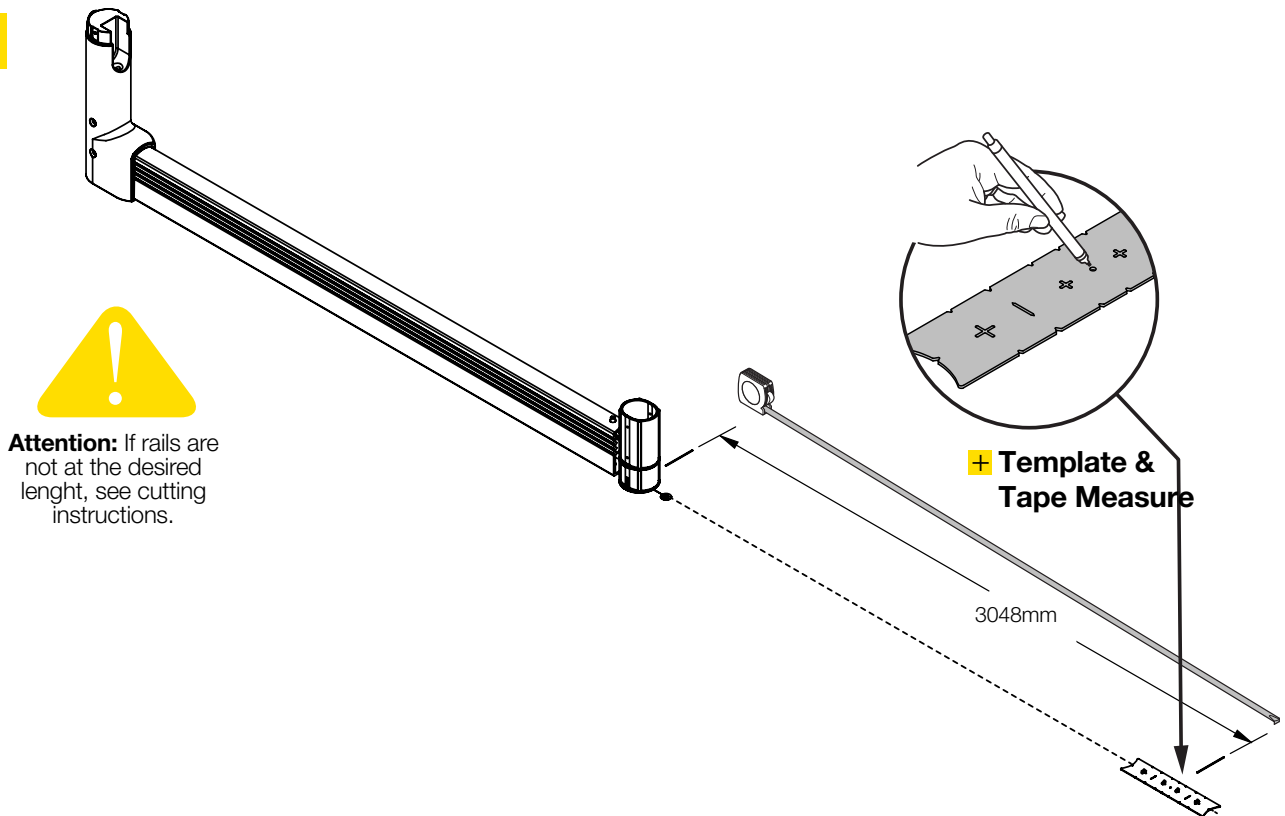

# Axelent Assembly instructions

» FlexCore Guardrail

10

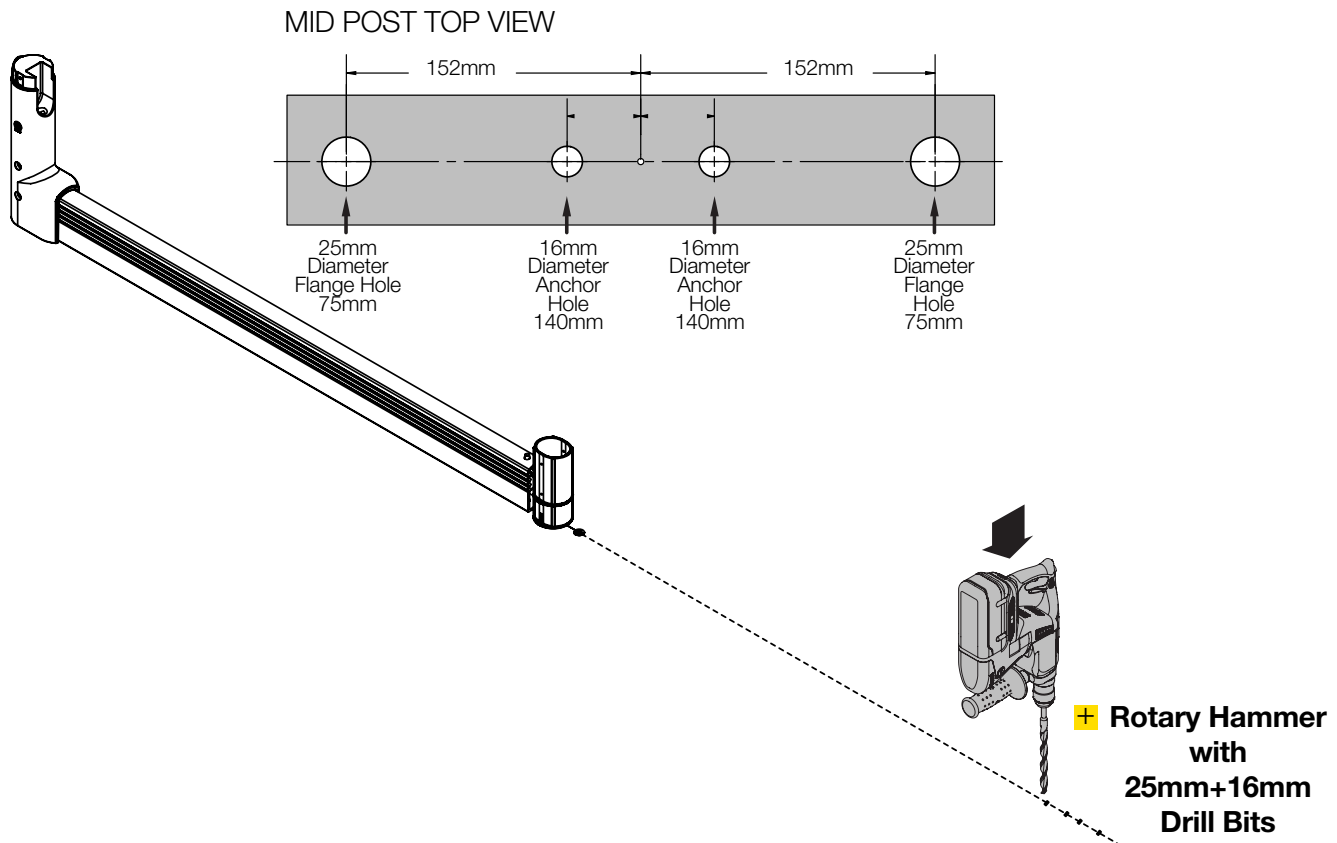

11

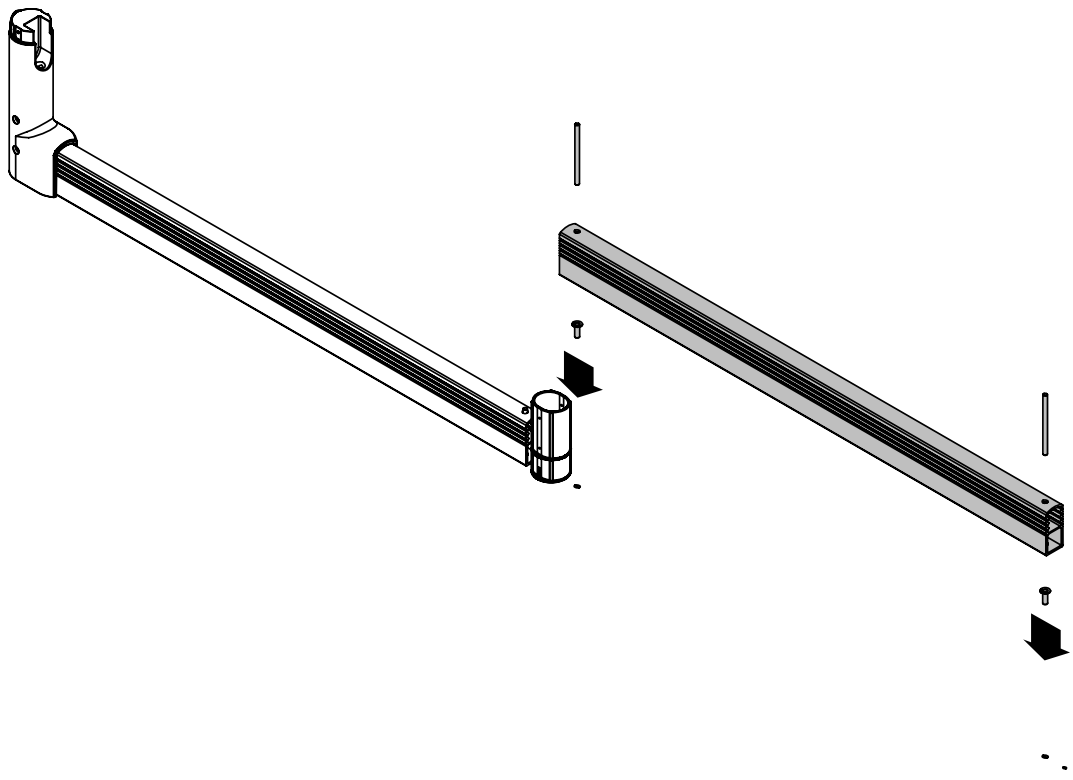

# Axelent Assembly instructions

» FlexCore Guardrail

12

+ Impact Driver with  
27mm Socket

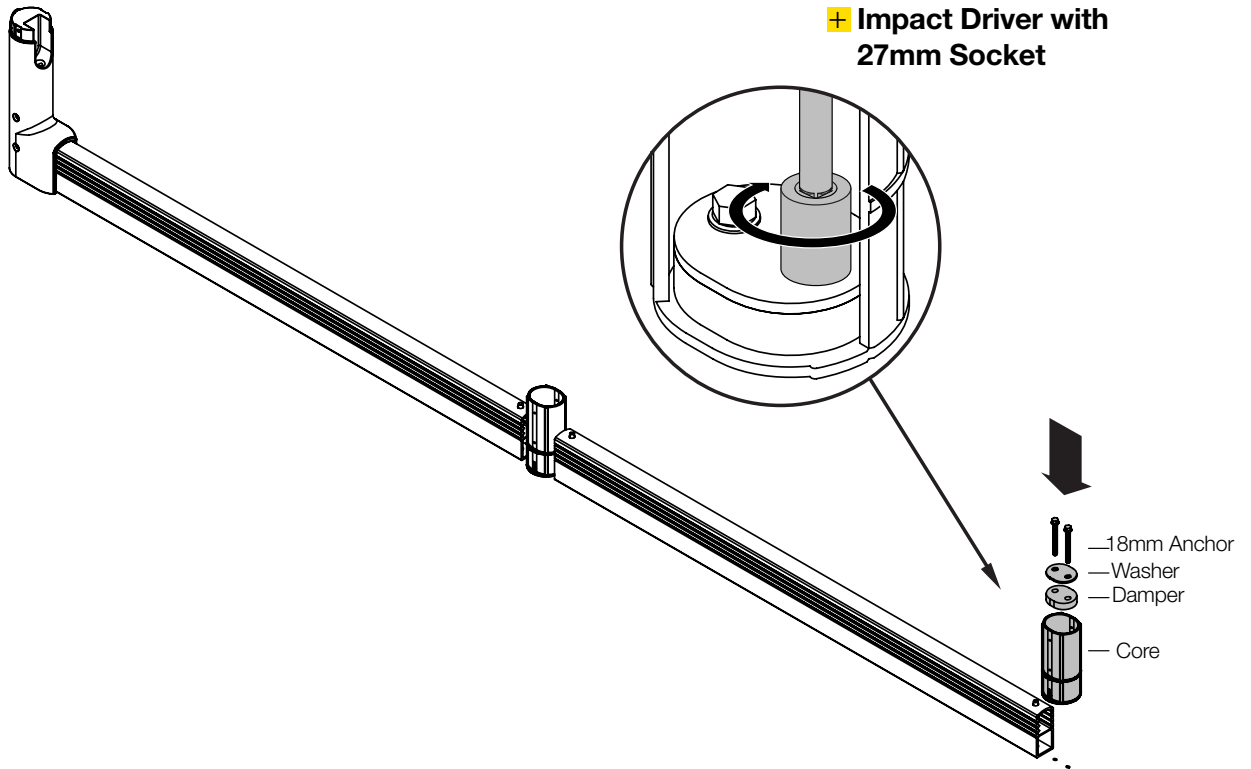

13

+ 5.5mm Hex Key

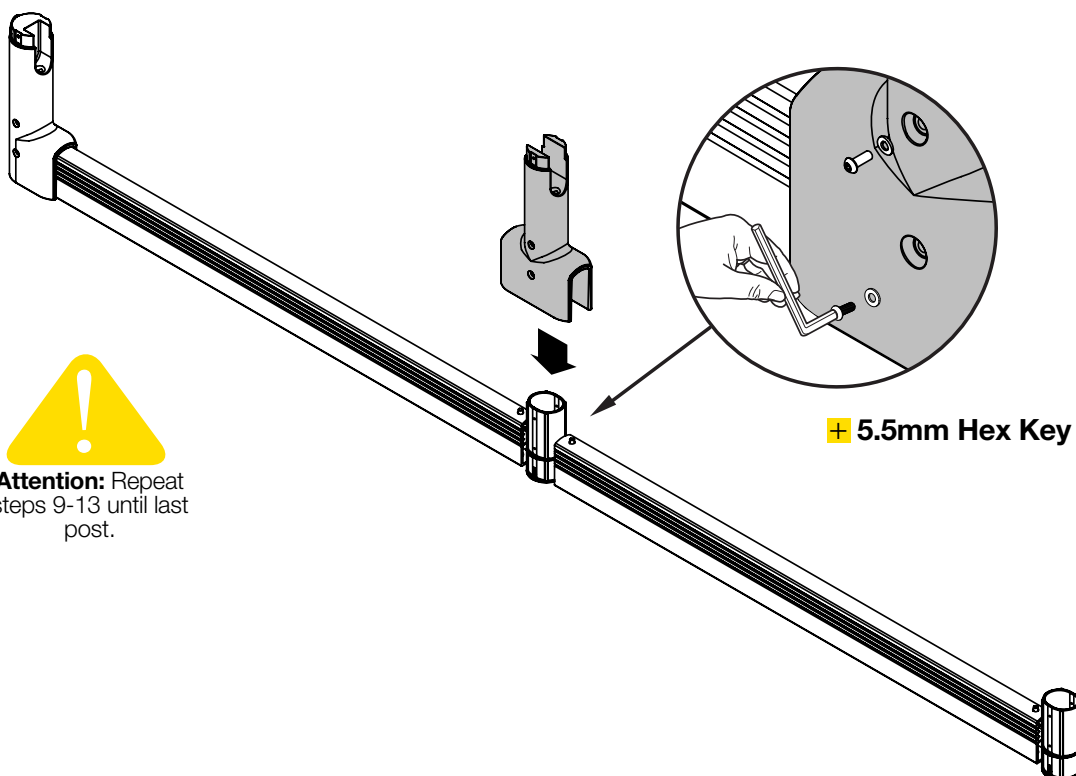

**Attention:** Repeat  
steps 9-13 until last  
post.

# Axelent Assembly instructions

» FlexCore Guardrail

14

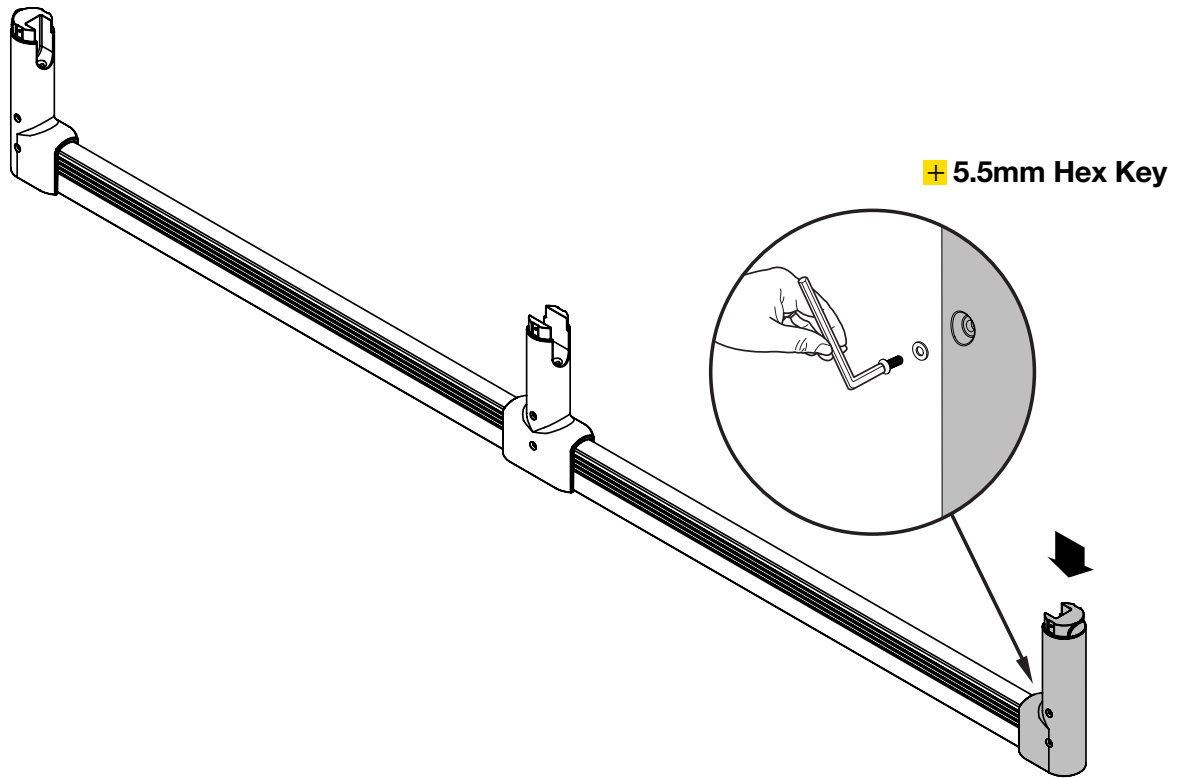

15

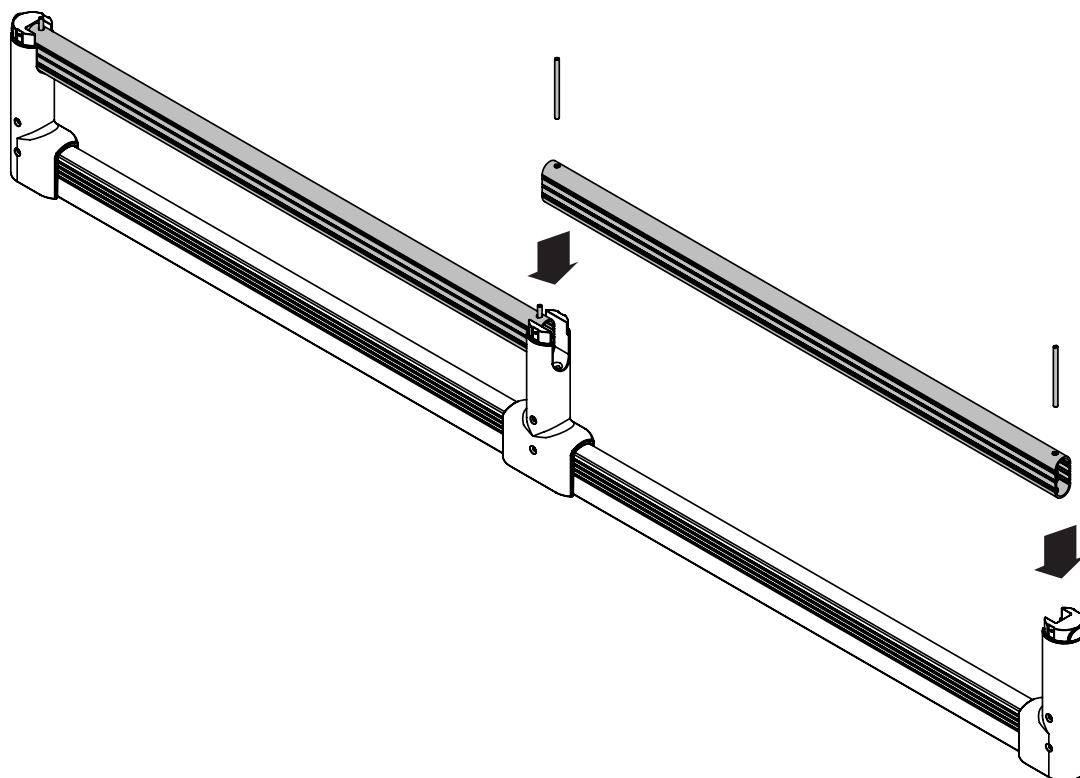



# Axelent Assembly instructions

» FlexCore Guardrail

16

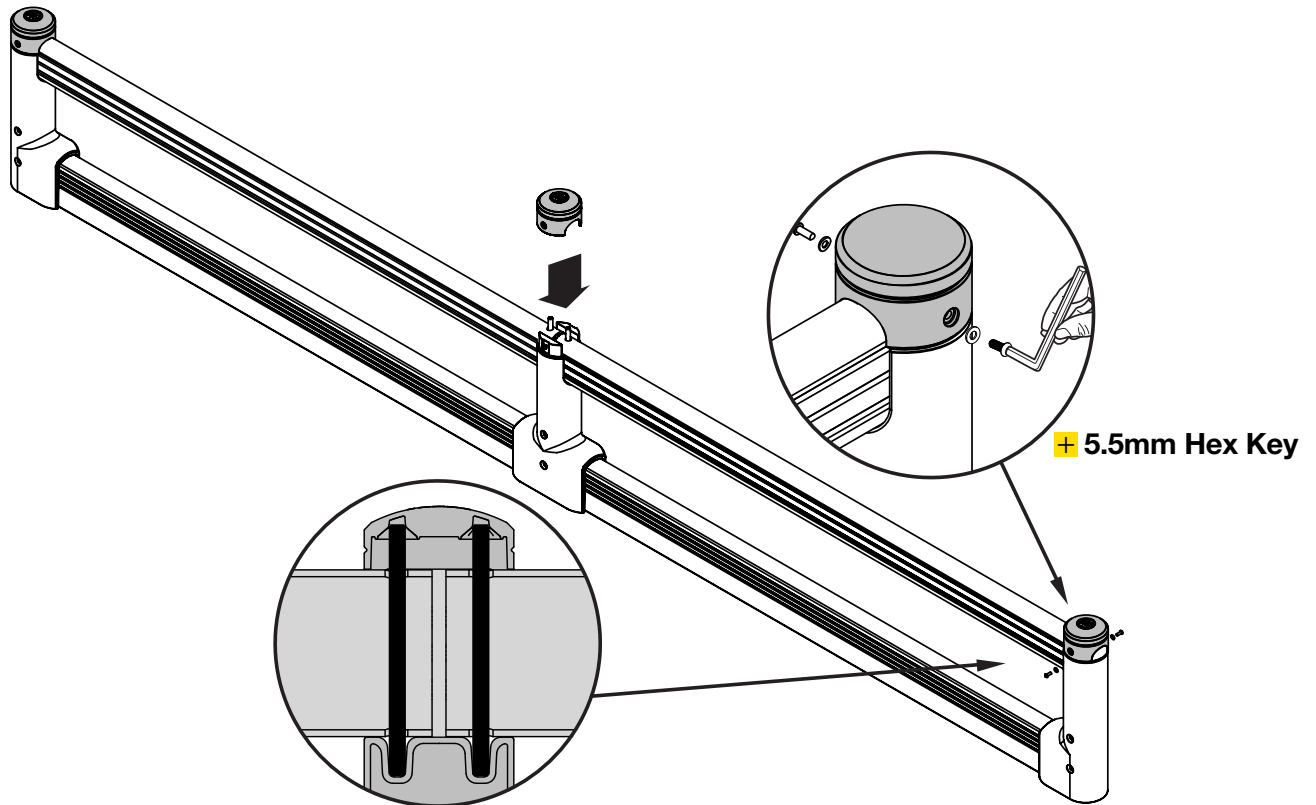

17

